

Pompe centrifughe monogirante estremamente silenziosa adatta ad applicazioni domestiche civili e industriali. La curva estremamente piatta garantisce pressioni pressoché costanti al variare della portata.

Single impeller centrifugal pumps, extremely silent suitable for household, civil and industrial applications, with a very flat curve to guarantee constant pressure even when the delivery.

Bombas centrífugas con un rodete extremadamente silenciosas apropiadas en aplicaciones domésticas civiles e industriales con una curva extremadamente plana; garantizan presiones casi constantes cuando varía el caudal.

Pompes centrifuges monoroue très silencieuses, aptes aux applications domestiques, civiles et industrielles. La courbe caractéristique très plate garantit des pressions quasiment constantes en cas de variation du débit.

**CARATTERISTICHE COSTRUTTIVE / CONSTRUCTION FEATURES
CARACTERÍSTICAS CONSTRUCTIVAS / CARACTÉRISTIQUES D'EXÉCUTION**

Corpo pompa Pump body Cuerpo bomba Corps de pompe	ghisa cast iron fundición fonte
Supporto motore Motor bracket Soporte motor Support moteur	ghisa ghisa o alluminio (CM75-100) cast iron cast iron or aluminium (CM75-100) fundición fundición o aluminio (CM75-100) fonte fonte ou aluminium (CM75-100)
Girante	Noryl® (CM45) Noryl® o ottone (CM50-310) Ottone (CM400-550)
Impeller	Noryl® (CM45) Noryl® or brass (CM50-310) Brass (CM400-550)
Rodete	Noryl® (CM45) Noryl® o latón (CM50-310) Latón (CM400-550)
Turbine	Noryl® (CM45) Noryl® ou laiton (CM50-310) Laiton (CM400-550)
Tenuta meccanica Mechanical seal Sello mecánico Garniture mécanique	ceramica-grafite ceramic-graphite cerámica-grafito céramique-graphite
Albero motore Motor shaft Eje motor Arbre moteur	acciaio AISI 416 (CM45-100) acciaio AISI 303 (CM160-550) stainless steel AISI 416 (CM45-100) stainless steel AISI 303 (CM160-550) acero AISI 416 (CM45-100) acero AISI 303 (CM160-550) acier AISI 416 (CM45-100) acier AISI 303 (CM160-550)
Temperatura del liquido Liquid temperature Temperatura del líquido Température du liquide	girante Noryl® o supporto alluminio: 0 - 50 °C girante ottone: 0 - 90 °C Noryl® impeller or aluminium bracket: 0 - 50 °C brass impeller: 0 - 90 °C rodete Noryl® o soporto alluminio: 0 - 50 °C rodete latón: 0 - 90 °C turbine Noryl® or support aluminium: 0 - 50 °C turbine laiton: 0 - 90 °C
Pressione di esercizio Operating pressure Presión de trabajo Pression de fonctionnement	max 6 bar (CM45-100) max 8 bar (CM160-550)
MOTORE / MOTOR / MOTOR / MOTEUR	
Motore 2 poli a induzione 2 pole induction motor Motor de 2 polos a inducción Moteur à induction à 2 pôles	3~ 230/400V-50Hz 1~ 230V-50Hz con termoprotettore with thermal protection con protección térmica avec protection thermique
Classe di isolamento Insulation class Clase de aislamiento Classe d'isolation	F
Grado di protezione Protection degree Grado de protección Protection	IP44

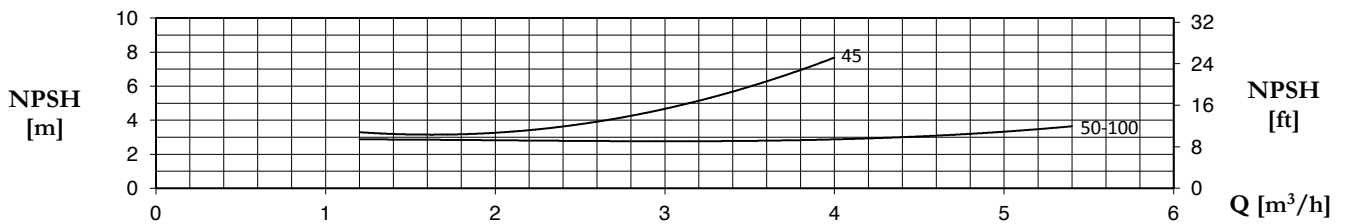
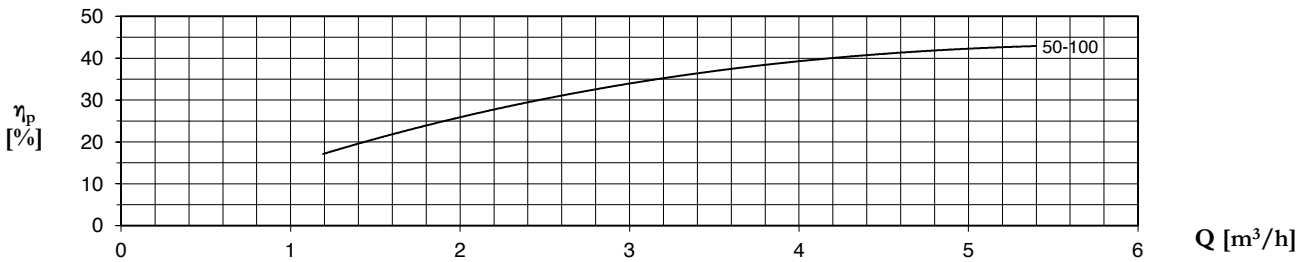
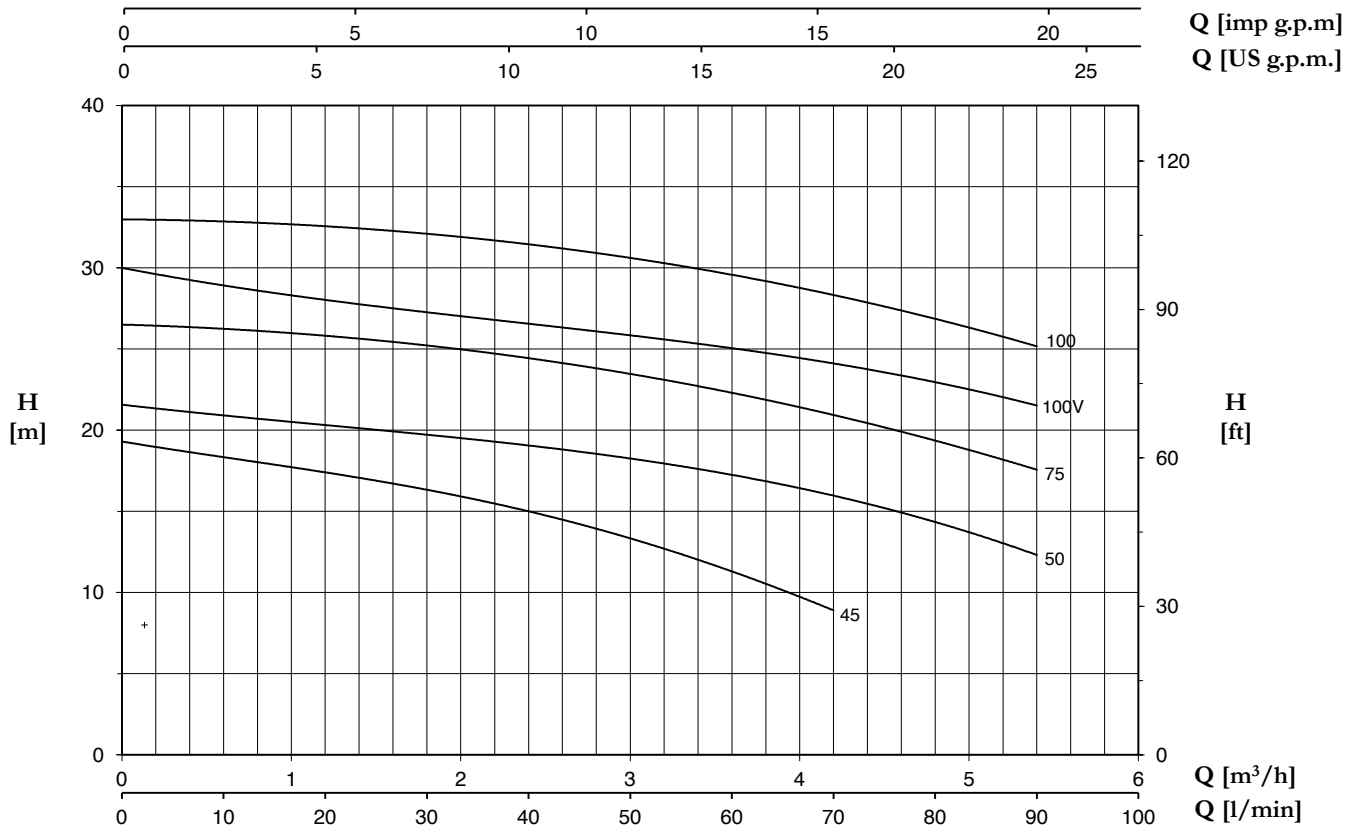

TYPE		P2		P1 (kW)		AMPERE		Q (m³/h - l/min)						
1~	3~					1~	3~	0	1,2	2,4	3,6	4,2	4,8	5,4
		(HP)	(kW)	1~	3~	1x230 V 50 Hz	3x400 V 50 Hz	0	20	40	60	70	80	90
CM 45	CMT 45	0,4	0,3	0,51	0,56	2,3	1	19,3	17,4	15	11,3	8,9	-	-
CM 50	CMT 50	0,5	0,37	0,59	0,65	2,8	1,1	21,5	20,5	19	17	15,8	15	12
CM 75	CMT 75	0,8	0,59	0,9	0,94	4,5	1,7	26,5	25,8	24,5	22,2	20,9	19,5	17,5
CM 100 V	-	1	0,74	1,05	-	4,6	-	30	28	26,6	25	24,1	23	21,5
CM 100	CMT 100	1	0,74	1,16	1,17	5,7	2	33	32,5	31,5	29,6	28,3	26,8	25,2

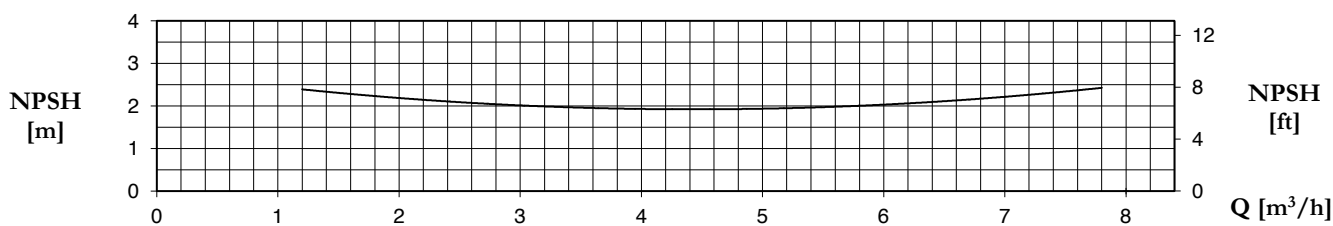
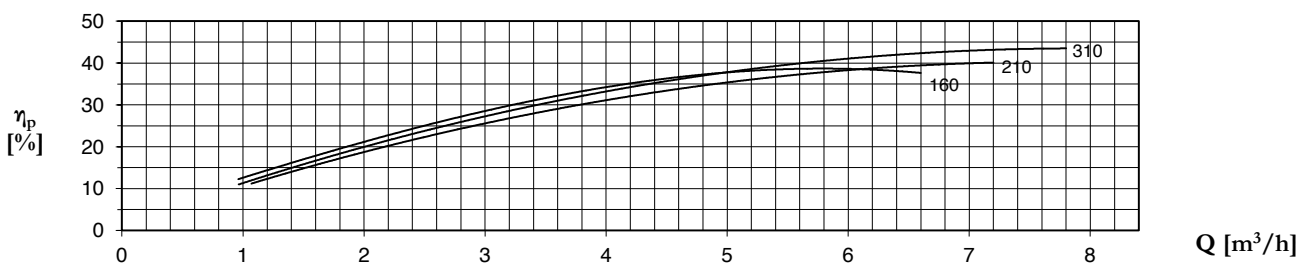
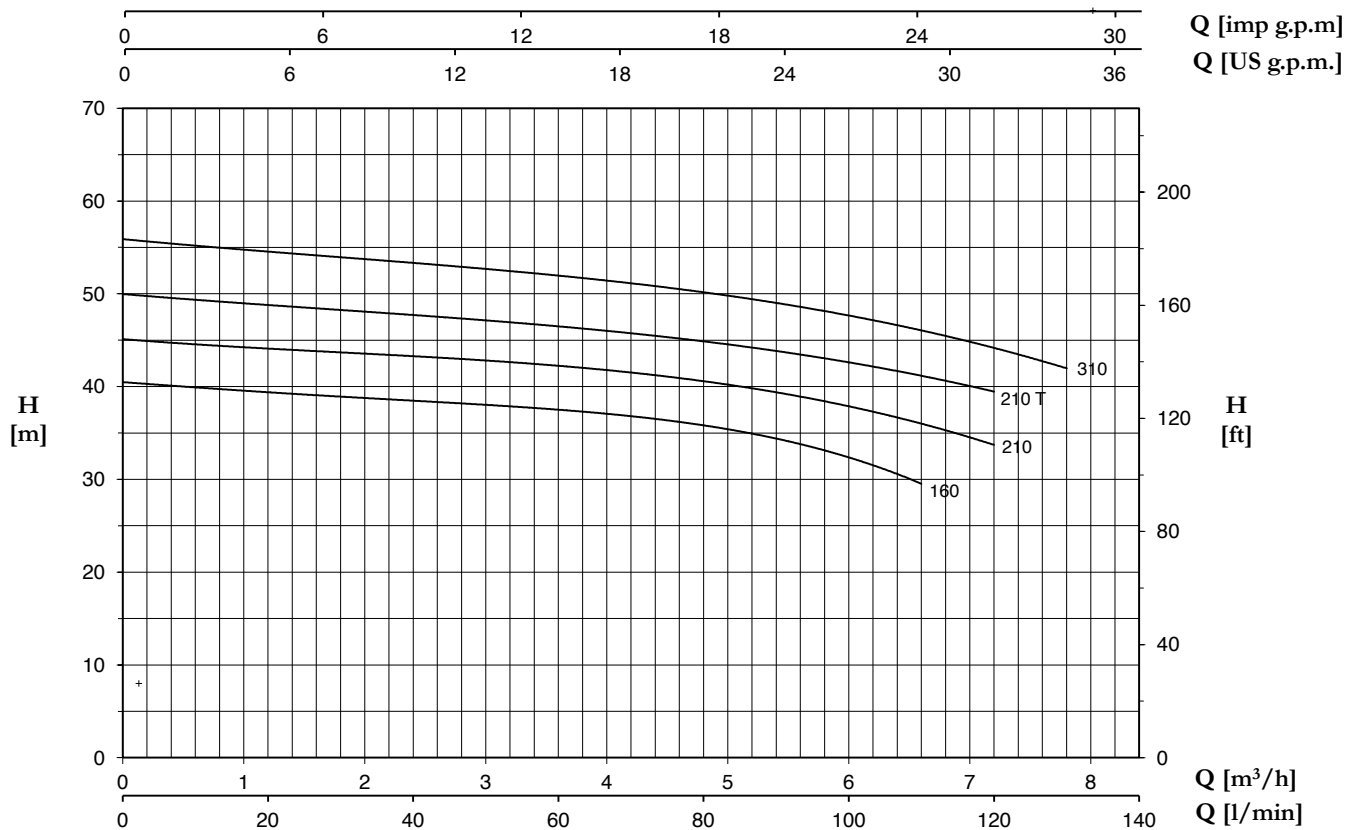

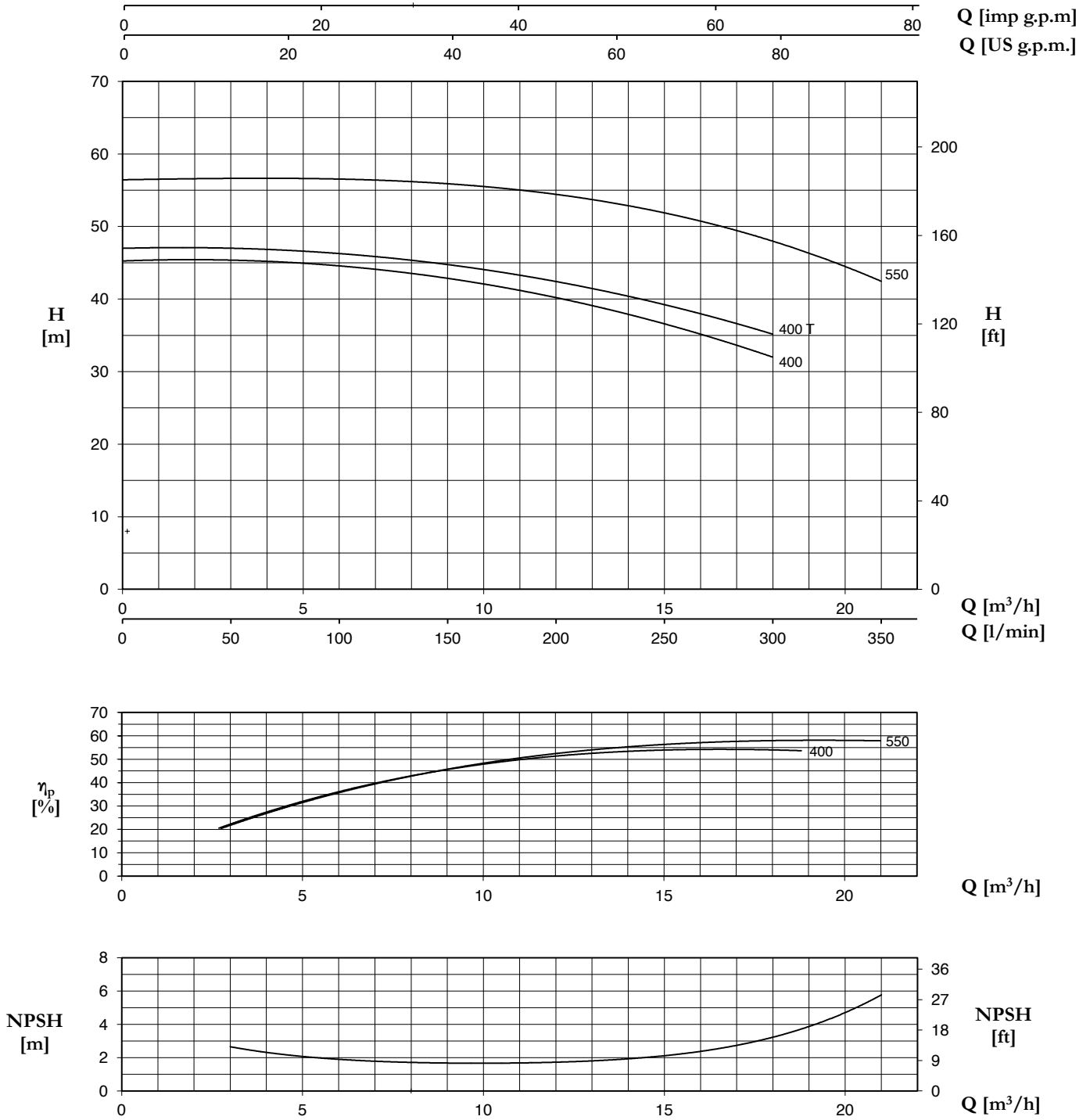

TYPE		P2		P1 (kW)		AMPERE		Q (m ³ /h - l/min)								
1~	3~					1~	3~	0	1,2	2,4	3,6	4,8	5,4	6,6	7,2	7,8
		(HP)	(kW)	1~	3~	1x230 V 50 Hz	3x400 V 50 Hz	H (m)								
CM 160/164	CMT 160/164	1,5	1,1	1,9	1,8	8,5	3,4	40,5	39,3	38,6	37,5	35,6	34,6	29,5	-	-
CM 210/214	-	2	1,5	2,2	-	10,3	-	45,1	44,1	43,3	42,3	40,5	39,2	36,4	33,5	-
-	CMT 210/214	2	1,5	-	2,43	-	4,9	50	48,7	47,8	46,5	44,9	43,7	41,3	39,4	-
CM 310/314	CMT 310/314	3	2,2	2,85	2,67	13,5	5,1	55,9	54,5	53,4	52	50,1	48,9	46,2	44,2	41,9

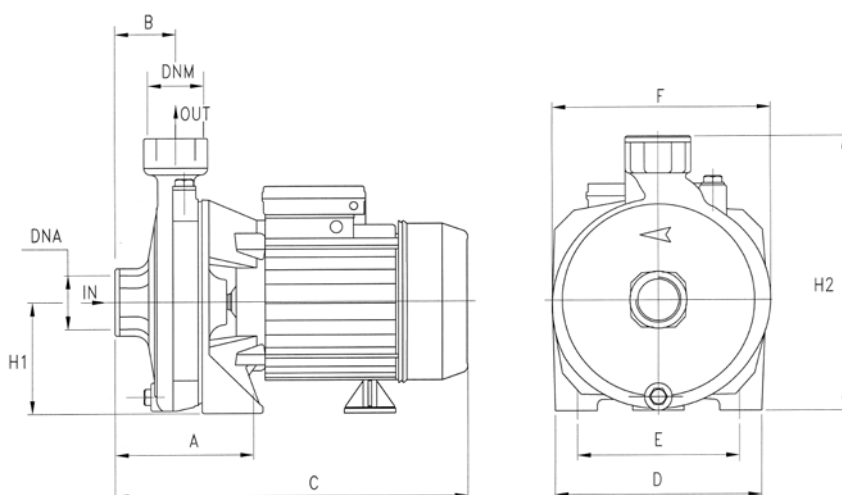

TYPE		P2		P1 (kW)		AMPERE		Q (m³/h - l/min)							
1~	3~	(HP)	(kW)	1~	3~	1~	3~	0	3	6	9	12	15	18	21
						0	50	100	150	200	250	300	350		
						1x230 V 50 Hz	3x400 V 50 Hz	H (m)							
CM 400	-	4	3,0	4,0	-	17,8	-	45,3	45,2	44,7	42,9	40,1	36,6	32	-
-	CMT 400	4	3,0	-	3,8	-	6,6	47	47	46,2	44,8	42,5	39,1	35,2	-
-	CMT 550	5,5	4,0	-	5,4	-	9,4	56,5	56,5	56,5	56	54,5	51,8	47,9	42,5



TYPE	DIMENSIONS (mm)													
	A	B	C	D	E	F	H1	H2	DNA	DNM	I	L	M	
CM 45	95	45.5	265	150	110	160	82	202	1" G	1" G	290	175	225	8,5
CM 50	95	45.5	265	150	110	160	82	202	1" G	1" G	290	175	225	9
CM 75	110	46.5	300	180	140	185	97	234	1" G	1" G	325	200	265	12.7
CM 100 V	110	46,5	300	180	140	185	97	234	1" G	1" G	325	200	265	13,5
CM 100	110	46.5	300	180	140	185	97	234	1" G	1" G	325	200	265	14
CM 160	117	46.5	348	220	180	225	115	285	1" G	1" G	370	240	315	22.5
CM 164	117	46.5	348	220	180	225	115	285	1" 1/4 G	1" G	370	240	315	22.5
CM 210	117	46.5	348	220	180	225	115	285	1" G	1" G	370	240	315	23
CM 214	117	46.5	348	220	180	225	115	285	1" 1/4 G	1" G	370	240	315	23
CM 310	117	46.5	M 410	220	180	225	115	285	1" G	1" G	370	240	315	M 27.5
			T 348											T 23.5
CM 314	117	46.5	M 410	220	180	225	115	285	1" 1/4 G	1" G	370	240	315	M 27.5
			T 348											T 23.5
CM 400	108	54	425	240	190	250	133	323	2" G	1" 1/4 G	440	270	360	39.8
CM 550	108	54	425	240	190	250	133	323	2" G	1" 1/4 G	440	270	360	39.8

TYPE				
	TRUCK		CONTAINER	
	PALLET (cm)	N° pumps	PALLET (cm)	N° pumps
CM 45-50	80x120x145	102	80x120x190	136
CM 75-100	85x110x145	65	85x110x195	91
CM 160-310	85x110x140	40	85x110x170	60
CM 310 M	85x110x150	24	85x110x180	30
CM 400-550	85x110x150	24	85x110x180	30

**CARATTERISTICHE COSTRUTTIVE / CONSTRUCTION FEATURES
CARACTERÍSTICAS CONSTRUCTIVAS / CARACTÉRISTIQUES D'EXÉCUTION**

Corpo pompa	ghisa
Pump body	cast iron
Cuerpo bomba	fundición
Corps de pompe	fonte
Supporto motore	ghisa
Motor bracket	cast iron
Soporte motor	fundición
Support moteur	fonte
Girante	Noryl® o ottone
Impeller	Noryl® or brass
Rodete	Noryl® o latón
Turbine	Noryl® ou laiton
Tenuta meccanica	ceramica-grafite
Mechanical seal	ceramic-graphite
Sello mecánico	cerámica-grafito
Garniture mécanique	céramique-graphite
Albero motore	acciaio AISI 416
Motor shaft	stainless steel AISI 416
Eje motor	acero AISI 416
Arbre moteur	acier AISI 416
Temperatura del liquido	girante Noryl®: 0 - 50 °C girante ottone: 0 - 90 °C
Liquid temperature	Noryl® impeller: 0 - 50 °C brass impeller: 0 - 90 °C
Temperatura del líquido	rodete de Noryl®: 0 - 50 °C rodete latón: 0 - 90 °C
Température du liquide	turbine en Noryl®: 0 - 50 °C turbine laiton: 0 - 90 °C
Pressione di esercizio	
Operating pressure	max 6 bar
Presión de trabajo	
Pression de fonctionnement	

MOTORE / MOTOR / MOTOR / MOTEUR

Motore 2 poli a induzione	3~ 230/400V-50Hz
2 pole induction motor	1~ 230V-50Hz
Motor de 2 polos a inducción	con termoprotettore with thermal protection
Moteur à induction à 2 pôles	con protezione térmica avec protection thermique
Classe di isolamento	
Insulation class	F
Clase de aislamiento	
Classe d'isolation	
Grado di protezione	
Protection degree	IP44
Grado de protección	
Protection	



Pompe centrifughe di media portata per piccole e medie applicazioni agricole. Dotate di girante aperta per consentire il passaggio di piccoli corpi solidi (Ø max. 10 mm.).

Medium delivery centrifugal pumps for small and medium agricultural applications. Open rotor which allows small solid items to pass through (Ø max 10 mm.).

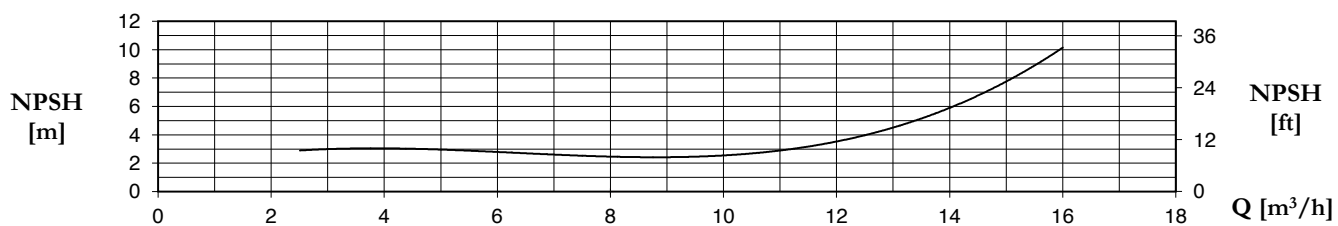
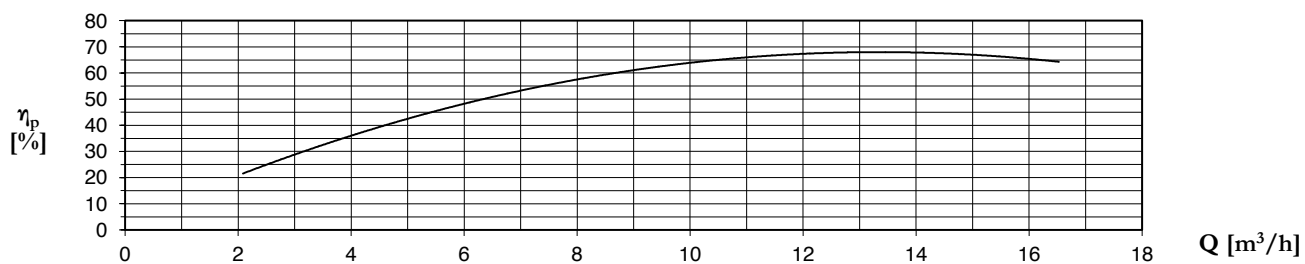
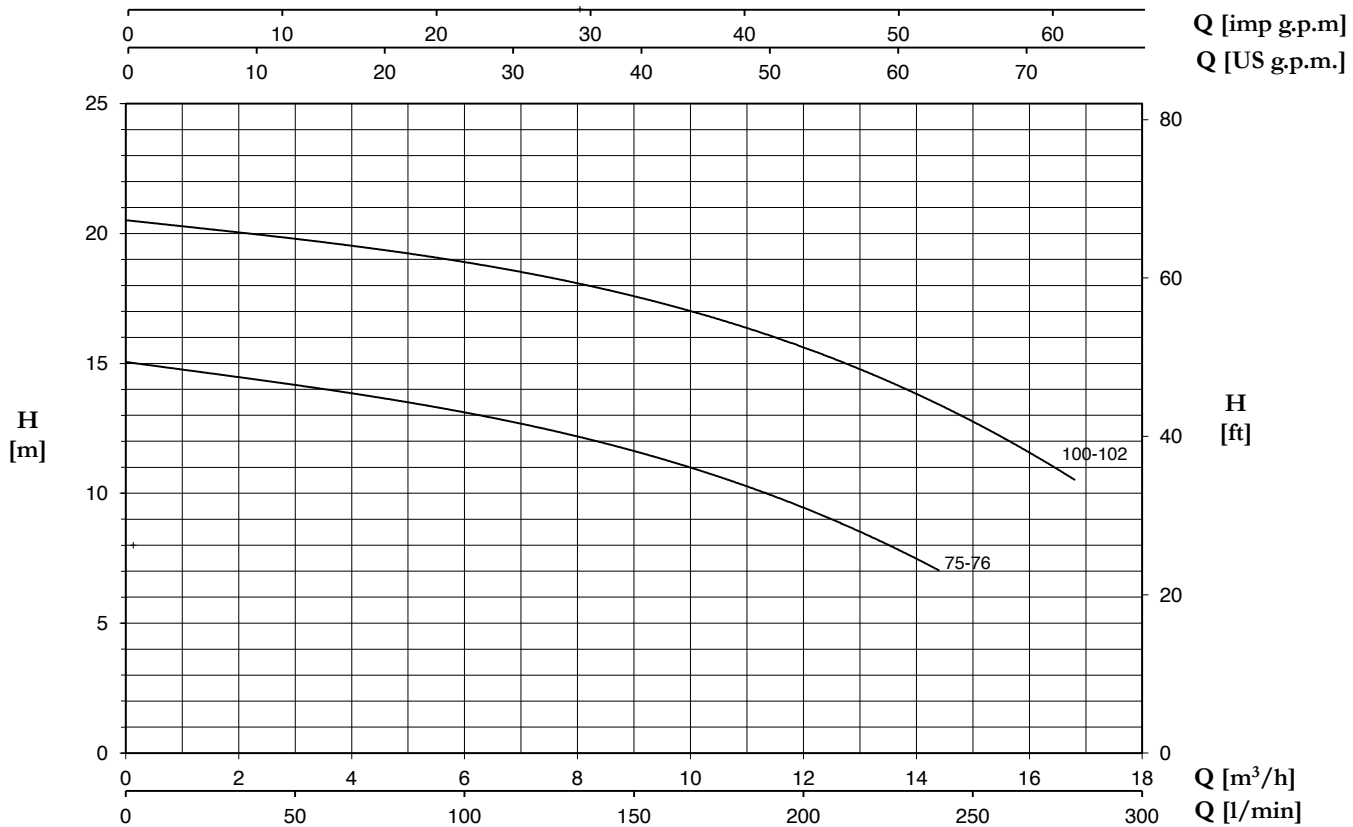

Bombas centrífugas de caudal mediano para aplicaciones agrícolas pequeñas y medianas. Dotadas de rodete abierto para permitir el paso de pequeños cuerpos sólidos (Ø máx. 10 mm).

Pompes centrifuges de débit moyen pour petites et moyennes applications agricoles. Elles sont munies d'une roue ouverte afin de permettre le passage de petits corps solides (Ø max. 10 mm.).

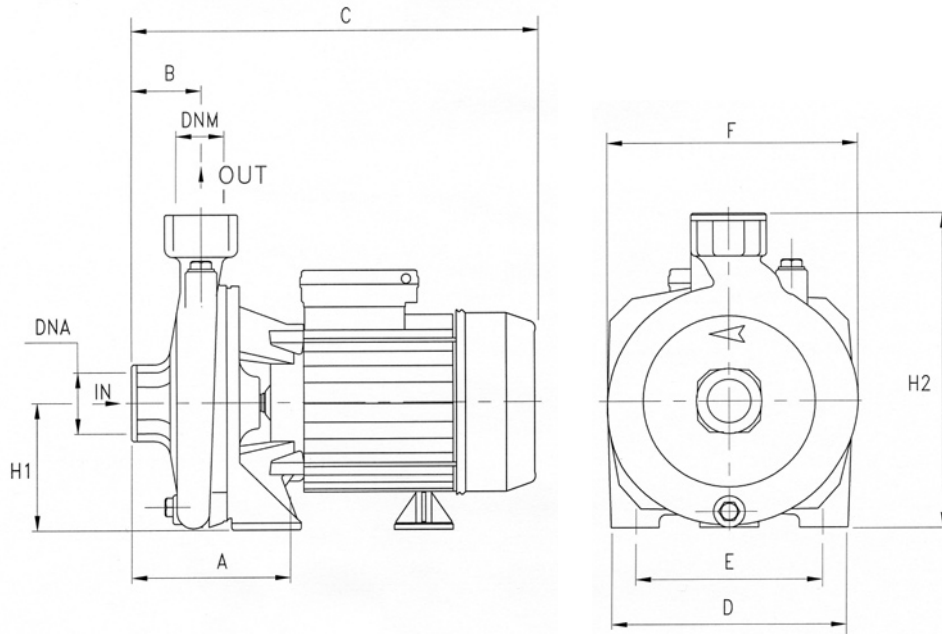

TYPE		P2		P1 (kW)		AMPERE		Q (m³/h - l/min)						
1~	3~					1~	3~	2,4	4,8	7,2	9,6	12	14,4	16,8
		(HP)	(kW)	1~	3~	40	80	120	160	200	240	280		
CR 75	CRT 75	0,8	0,59	0,73	0,83	3,4	1,5	14,5	13,5	12,5	11,3	9,5	7	-
CR 100	CRT 100	1	0,74	1,14	1,2	5,3	2,4	20	19,2	18,5	17,3	15,5	13,5	10,5
CR 76	CRT 76	0,8	0,59	0,73	0,83	3,4	1,5	14,5	13,5	12,5	11,3	9,5	7	-
CR 102	CRT 102	1	0,74	1,14	1,2	5,3	2,4	20	19,2	18,5	17,3	15,5	13,5	10,5



TYPE	DIMENSIONS (mm)													
	A	B	C	D	E	F	H1	H2	DNA	DNM	I	L	M	
CR 75	120	45	308	155	115	170	97	222	1"1/2 G	1"1/4 G	325	200	265	12.2
CR 100	120	45	308	155	115	170	97	222	1"1/2 G	1"1/4 G	325	200	265	13.5
CR 76	120	45	308	155	115	170	97	222	1"1/2 G	1"1/2 G	325	200	265	12.2
CR 102	120	45	308	155	115	170	97	222	1"1/2 G	1"1/2 G	325	200	265	13.5

TYPE				
	TRUCK		CONTAINER	
	PALLET (cm)	N° pumps	PALLET (cm)	N° pumps
CR	85x110x145	65	85x110x195	91



CS 75/2



CST 400/3

Pompe centrifughe monogiranti da scorrimento a media e alta portata caratterizzate da bocche di mandata da 2", 3" e 4"; trovano primaria applicazione nel campo dell'agricoltura e in tutte le applicazioni in cui una consistente portata è richiesta.

Single impeller centrifugal pumps, medium sliding high delivery with 2", 3" and 4" delivery openings; mainly used in agriculture and applications requiring high level delivery.

Bombas centrífugas con un rodete de desplazamiento de caudal medio y alto caracterizadas por bocas de salida de 2", 3" y 4"; encuentran aplicación primaria en el campo de la agricultura y en todas las aplicaciones en las que se solicita un caudal consistente.

Pompes de circulation centrifuges monoroue à débit moyen et élevé, caractérisées par des brides de refoulement de 2", 3" et 4"; elles trouvent leur application principale en agriculture et dans toutes les applications qui nécessitent un débit élevé.

**CARATTERISTICHE COSTRUTTIVE / CONSTRUCTION FEATURES
CARACTERÍSTICAS CONSTRUCTIVAS / CARACTÉRISTIQUES D'EXÉCUTION**

Corpo pompa	ghisa
Pump body	cast iron
Cuerpo bomba	fundición
Corps de pompe	fonte
Supporto motore	ghisa
Motor bracket	cast iron
Soporte motor	fundición
Support moteur	fonte
Girante	ghisa / ottone (CSB)
Impeller	cast iron / brass (CSB)
Rodete	fundición / latón (CSB)
Turbine	fonte / laiton (CSB)
Tenuta meccanica	ceramica-grafite
Mechanical seal	ceramic-graphite
Sello mecánico	cerámica-grafito
Garniture mécanique	céramique-graphite
Albero motore	acciaio AISI 303 acciaio AISI 416 (CS 75-100)
Motor shaft	stainless steel AISI 303 stainless steel AISI 416 (CS 75-100)
Eje motor	acero AISI 303 acero AISI 416 (CS 75-100)
Arbre moteur	acier AISI 303 acier AISI 416 (CS 75-100)
Temperatura del liquido	
Liquid temperature	0 - 90 °C
Temperatura del liquido	
Température du liquide	
Pressione di esercizio	
Operating pressure	max 6 bar
Presión de trabajo	
Pression de fonctionnement	
MOTORE / MOTOR / MOTOR / MOTEUR	
Motore 2 poli a induzione	3~ 230/400V-50Hz
2 pole induction motor	1~ 230V-50Hz
Motor de 2 polos a inducción	con termoprotettore with thermal protection
Moteur à induction à 2 pôles	con protezione térmica avec protection thermique
Classe di isolamento	
Insulation class	F
Clase de aislamiento	
Classe d'isolation	
Grado di protezione	
Protection degree	IP44
Grado de protección	
Protection	

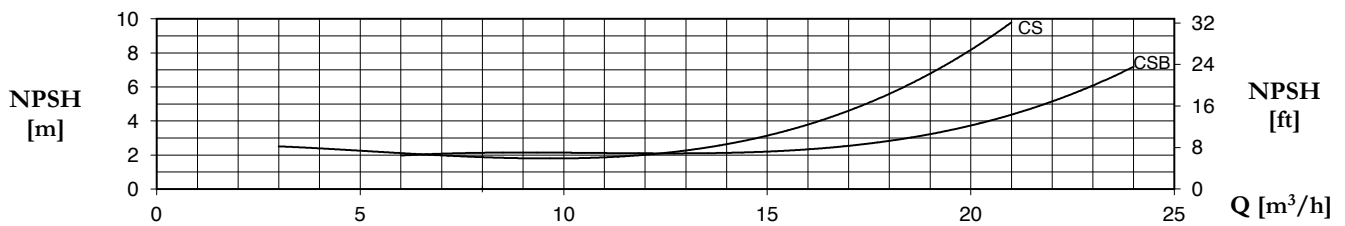
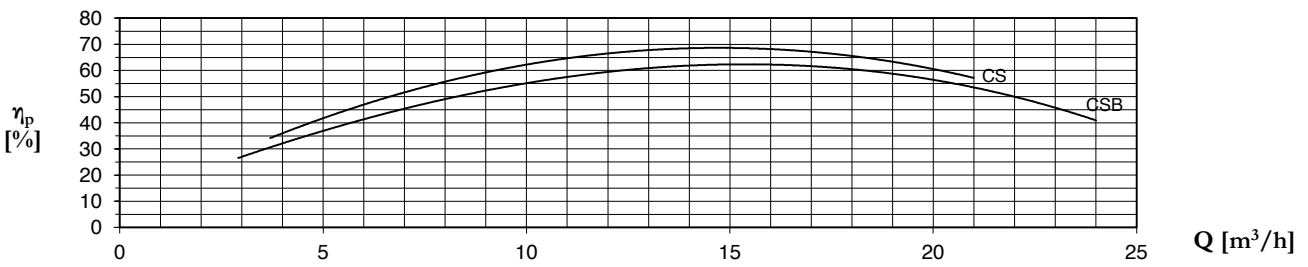
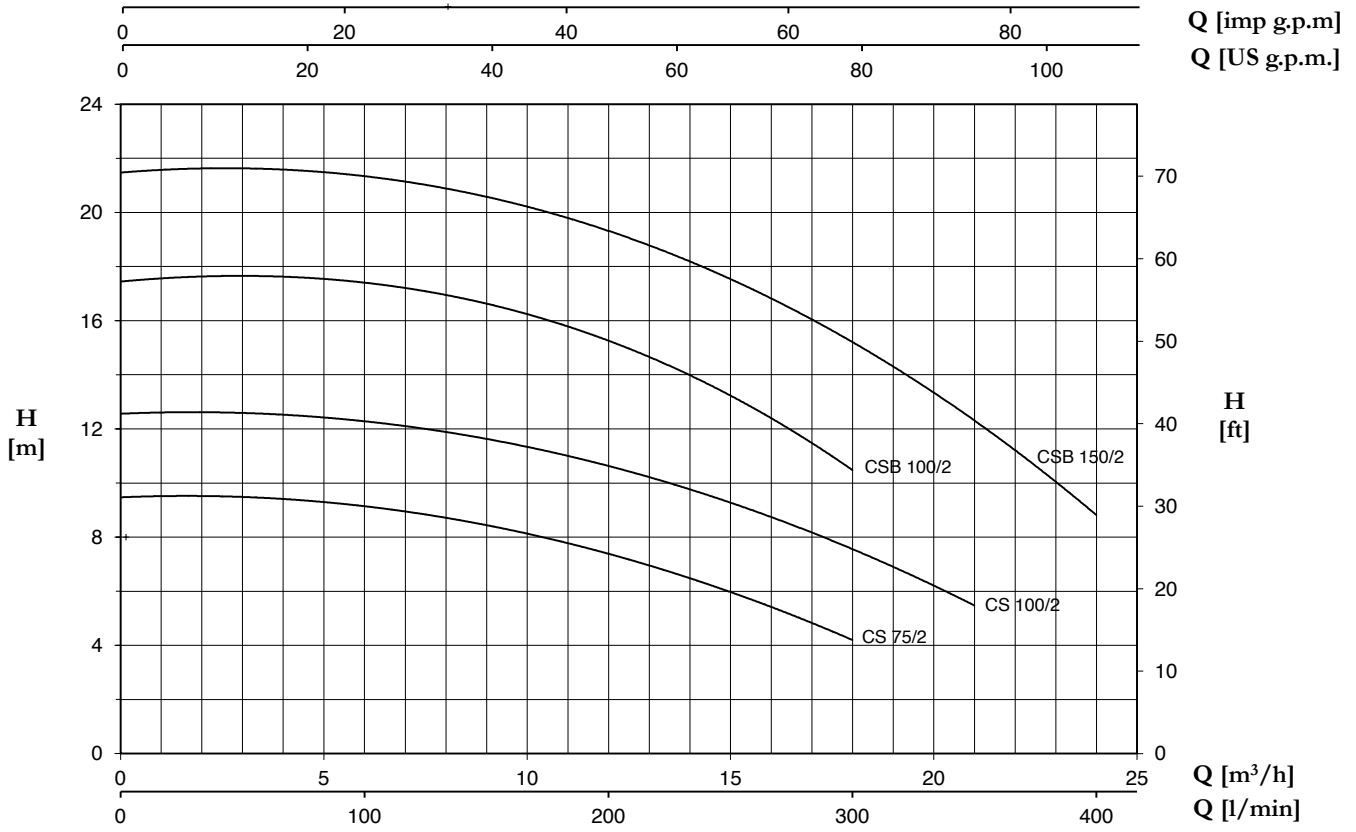

TYPE		P2		P1 (kW)		AMPERE		Q (m³/h - l/min)								
1~	3~					1~	3~	0	3	6	9	12	15	18	21	24
		(HP)	(kW)	1~	3~	1x230 V 50 Hz	3x400 V 50 Hz	0	50	100	150	200	250	300	350	400
		H (m)														
CS 75/2	CST 75/2	0,8	0,59	0,63	0,7	2,9	1,3	9,5	9,4	9,2	8,5	7,3	6	4,2	-	-
CS 100/2	CST 100/2	1	0,74	0,92	1,05	4,3	2,3	12,6	12,5	12,3	11,7	10,6	9,3	7,5	5,5	-
CSB 100/2	-	1	0,74	1,23	-	6	-	17,5	17,5	17,5	16,7	15,2	13,2	10,5	-	-
CSB 150/2	CSBT 150/2	1,5	1,1	1,78	1,65	8,5	3	21,5	21,5	21,5	20,6	19,2	17,5	15,3	12,3	8,8

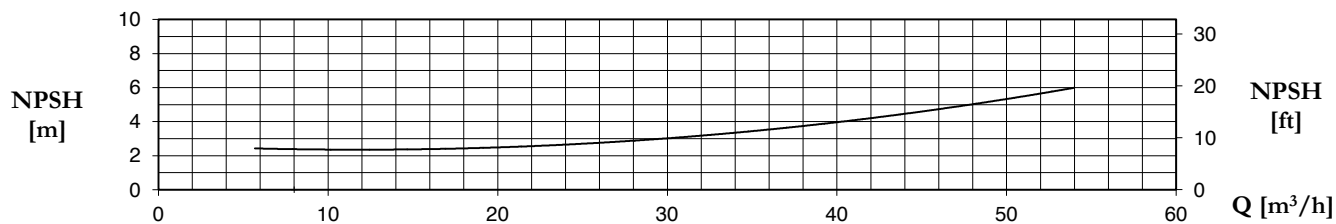
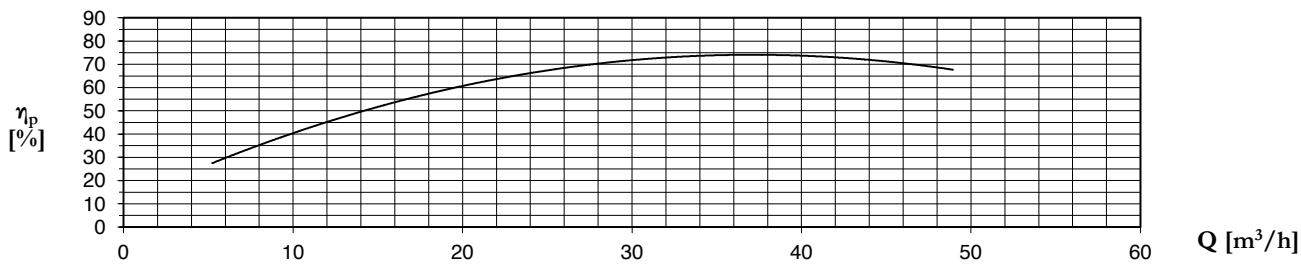
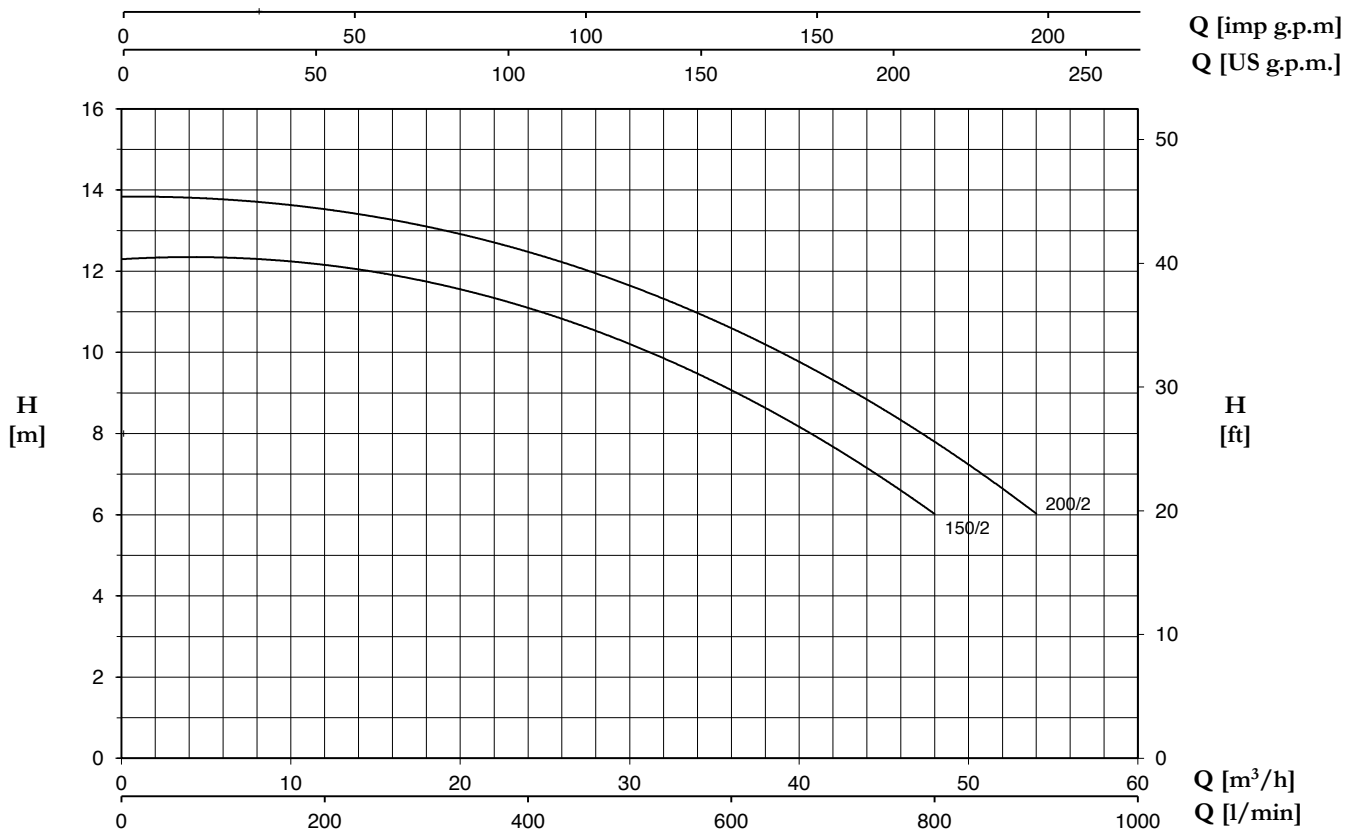

TYPE		P2		P1 (kW)		AMPERE		Q (m ³ /h - l/min)									
1~	3~	(HP)	(kW)	1~	3~	1~	3~	0	6	12	18	24	30	36	42	48	54
								0	100	200	300	400	500	600	700	800	900
								H (m)									
						1x230 V 50 Hz	3x400 V 50 Hz										
CS 150/2	CST 150/2	1,5	1,1	1,85	1,8	8,8	3,3	12,3	12,3	12,2	11,8	11,0	10,2	9,1	7,7	6	-
CS 200/2	CST 200/2	2	1,5	2,1	2,1	10	3,9	13,8	13,8	13,6	13,1	12,4	11,6	10,6	9,4	7,8	6

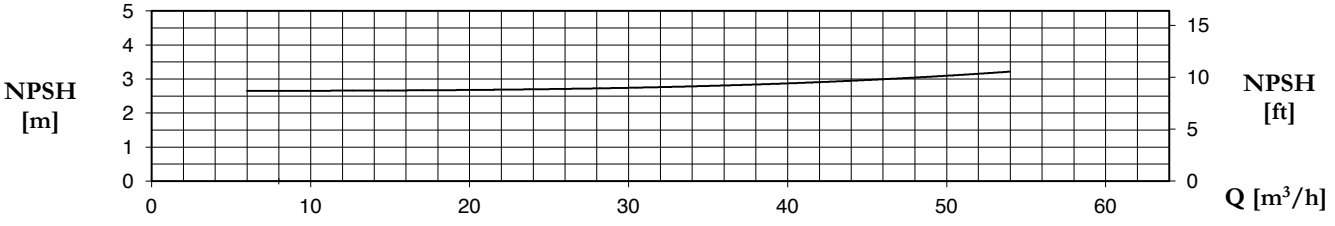
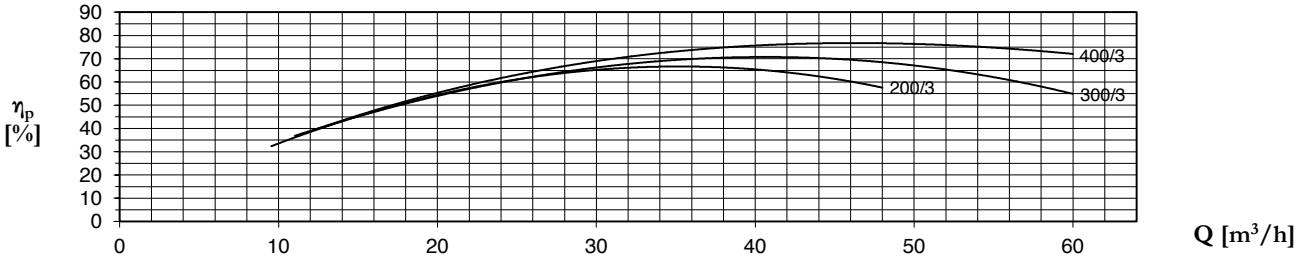
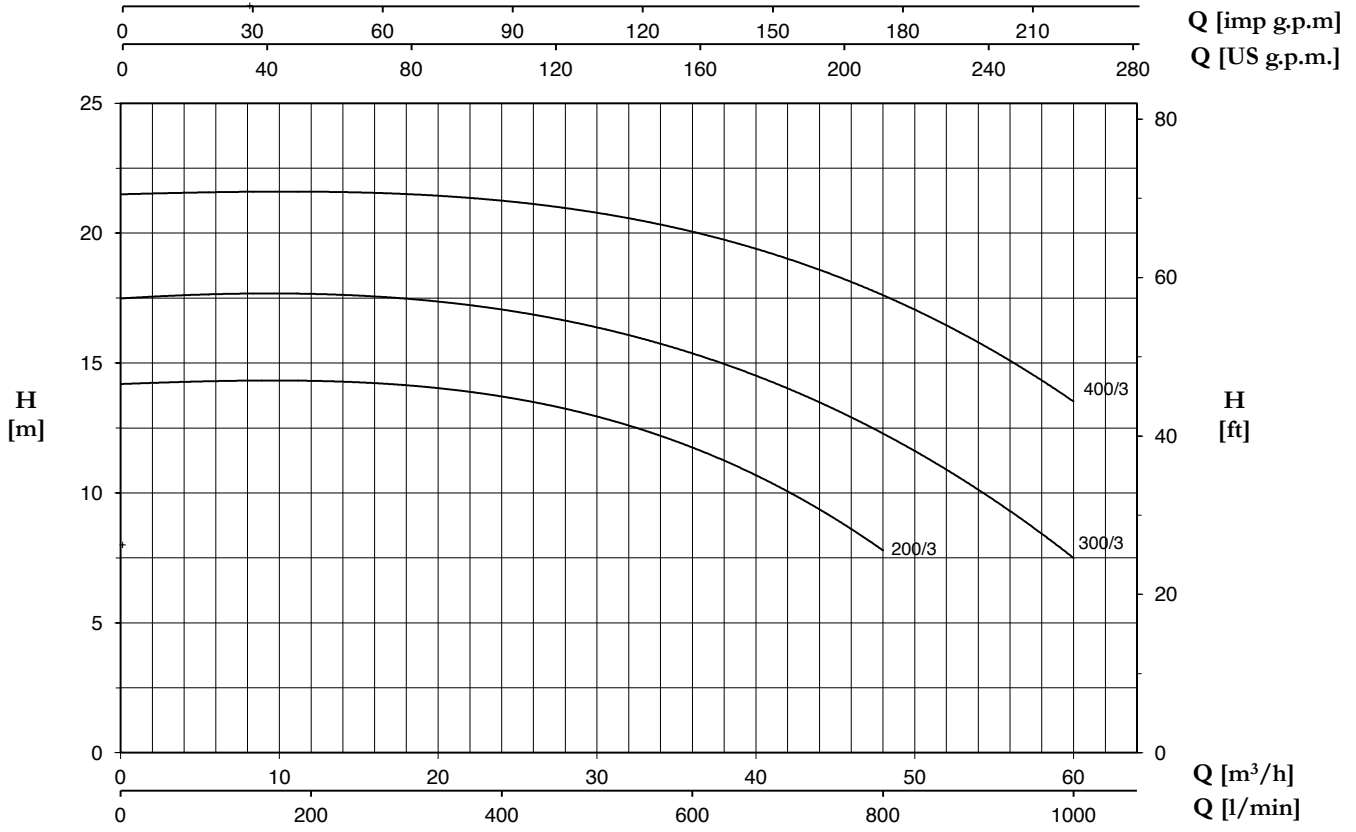

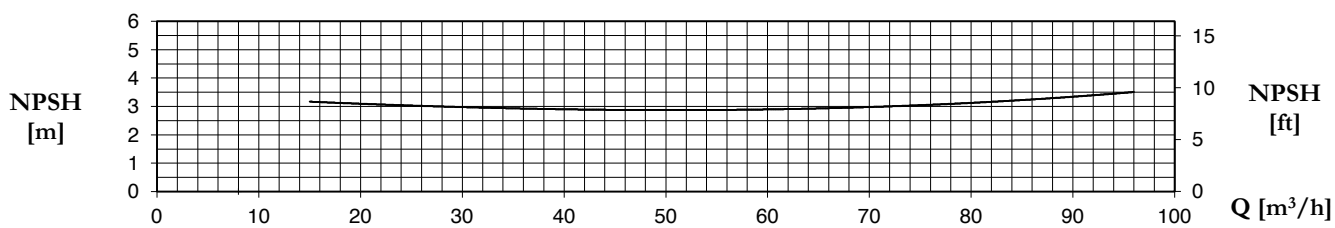
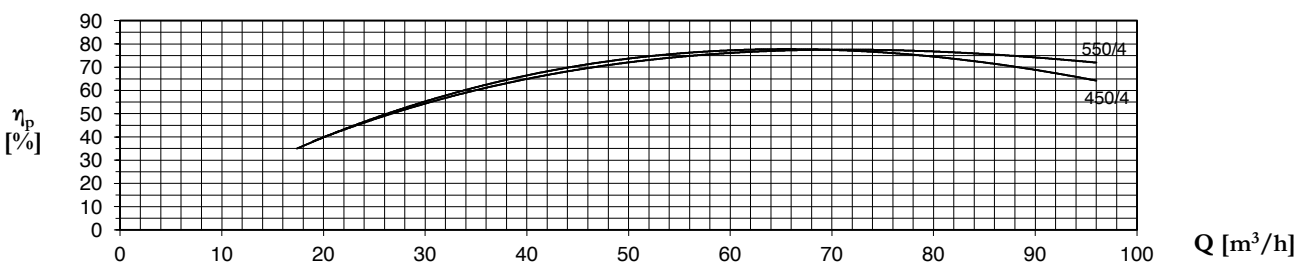
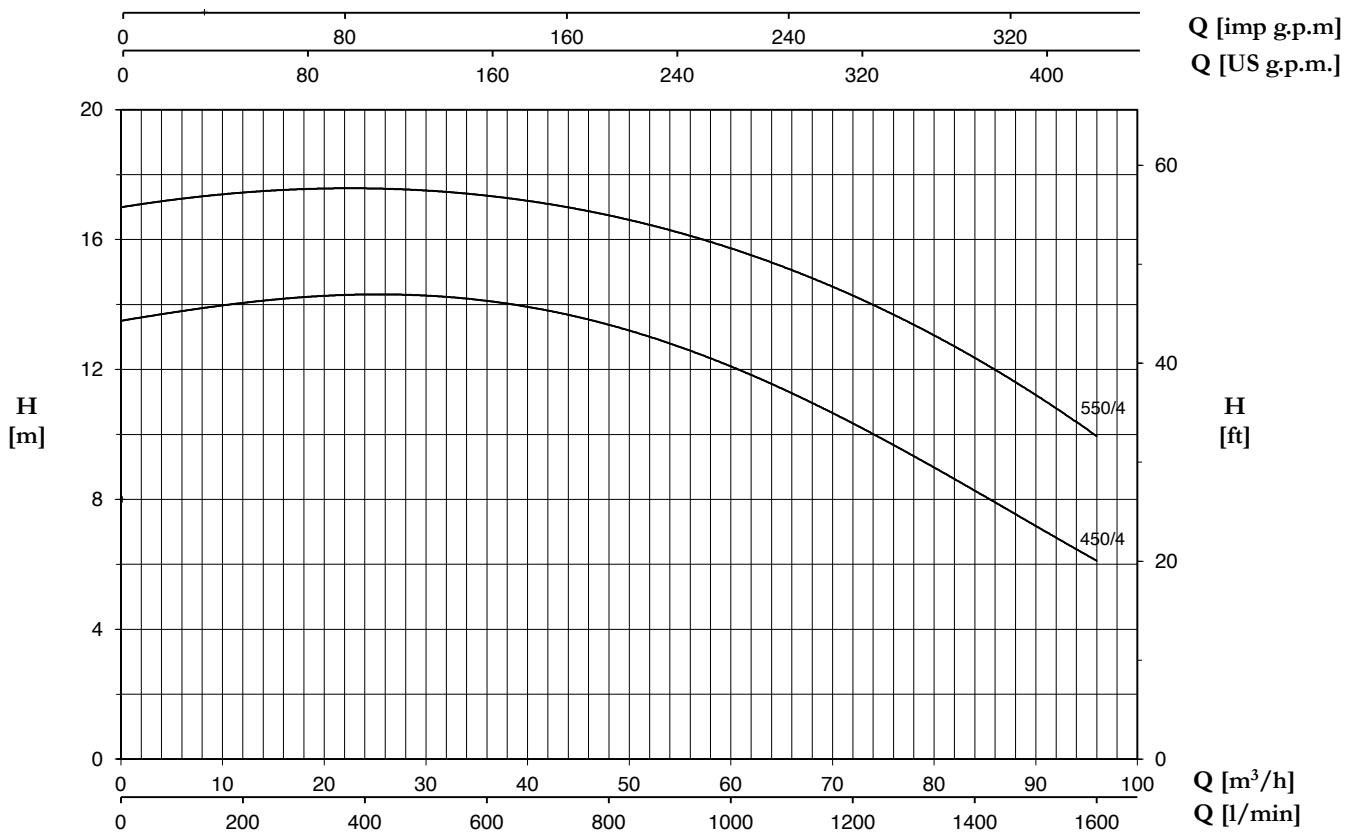

TYPE		P2		P1 (kW)		AMPERE		Q (m³/h - l/min)					
1~	3~	(HP)	(kW)	1~	3~	1~	3~	0	15	24	36	48	60
								0	250	400	600	800	1000
								H (m)					
CS 200/3	CST 200/3	2	1,5	2,35	2,15	11	3,6	14,2	14,2	13,8	11,7	7,8	-
CS 300/3	CST 300/3	3	2,2	3,3	2,9	15	4,9	17,5	17,5	17,2	15,3	12,3	7,5
-	CST 400/3	4	3	-	4	-	6,7	21,5	21,5	21,4	19,9	17,7	13,5

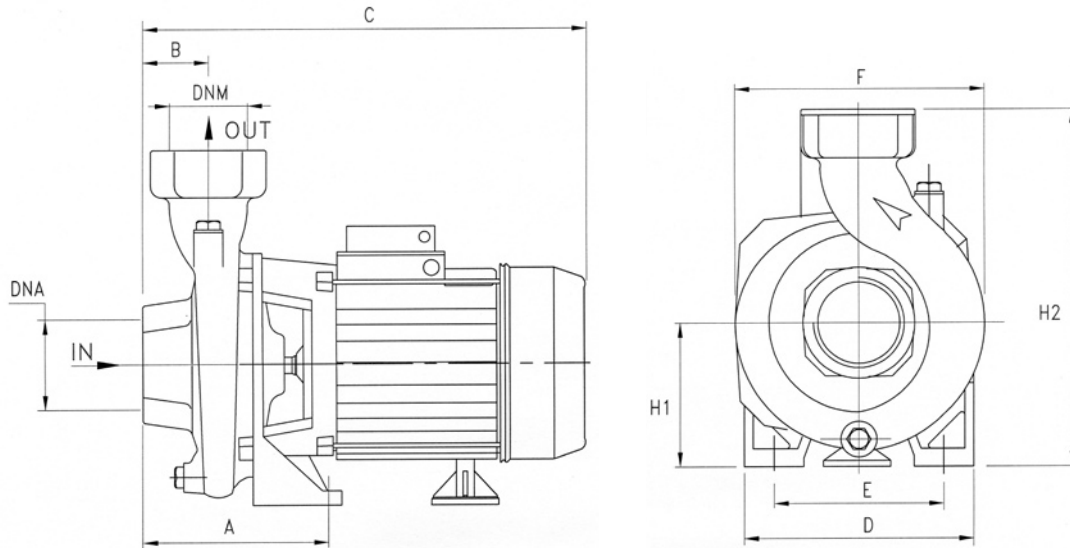

TYPE		P2		P1 (kW)		AMPERE		Q (m³/h - l/min)						
1~	3~					1~	3~	0	36	48	60	72	84	96
		(HP)	(kW)	1~	3~	1x230 V 50 Hz	3x400 V 50 Hz	H (m)						
CS 450/4	CST 450/4	4	3	3,7	3,6	18	6,2	13,5	14,1	13,4	12,1	10,3	8,3	6,1
-	CST 550/4	5,5	4	-	5,05	-	8,8	17	17,3	16,8	15,7	14,4	12,2	10,0



TYPE	DIMENSIONS (mm)													
	A	B	C	D	E	F	H1	H2	DNA	DNM	I	L	M	
CS 75/2	127	45	315	155	115	178	97	247	2" G	2" G	340	195	280	14.2
CS 100/2	127	45	315	155	115	178	97	247	2" G	2" G	340	195	280	15.5
CS 150/2	150	53	370	180	140	218	115	285	2" G	2" G	390	230	325	23.3
CS 200/2	150	53	370	180	140	218	115	285	2" G	2" G	390	230	325	24.3
CSB 100/2	130	70	365	180	130	195	90	240	2" G	2" G	390	230	325	18.2
CSB 150/2	130	70	365	180	130	195	90	240	2" G	2" G	390	230	325	19.1
CS 200/3	176,5	80	455	200	140	225	112	292	3" G	3" G	480	245	330	28.3
CS 300/3	176,5	80	455	200	140	225	112	292	3" G	3" G	480	245	330	31.5
CST 400/3	176,5	80	455	200	140	225	112	292	3" G	3" G	480	245	330	31.6
CST 450/4	165	85	480	220	160	250	130	330	4" G	4" G	510	275	365	41.1
CST 550/4	165	85	480	220	160	250	130	330	4" G	4" G	510	275	365	41.1

TYPE				
	TRUCK		CONTAINER	
	PALLET (cm)	N° pumps	PALLET (cm)	N° pumps
CS 75/2-100/2	90x110x145	65	90x110x195	91
CS 150/2-200/2	85x110x140	40	85x110x205	60
CS 200/3-300/3	85x110x150	30	85x110x180	60
CS 450/4-550/4	80x120x150	30	80x120x180	60



Pompe centrifughe che abbinano medie prevalenze a portate medio alte; adatte per irrigazioni a pioggia e in generale dove oltre alla silenziosità viene richiesta una lieve oscillazione di pressione al variare della portata.

Centrifugal pumps that combine medium head with medium-high delivery; ideal for sprinkle irrigation and in applications where quiet operations are requested and only slight pressure change as the delivery changes.

Bombas centrífugas que combinan prevalencias medias con caudales medio-altos; apropiadas para riegos por aspersión en general donde además del silencio se solicita una leve oscilación de presión cuando varía el caudal.

Pompes centrifuges qui associent des hauteurs manométriques moyennes à des débits moyens-élevés; adaptées pour l'irrigation par aspersion et, en général, quand, en plus du bruit limité, il faut assurer une légère oscillation de pression en fonction de la variation du débit.

**CARATTERISTICHE COSTRUTTIVE / CONSTRUCTION FEATURES
CARACTERÍSTICAS CONSTRUCTIVAS / CARACTÉRISTIQUES D'EXÉCUTION**

Corpo pompa	ghisa
Pump body	cast iron
Cuerpo bomba	fundición
Corps de pompe	fonte
Supporto motore	ghisa
Motor bracket	cast iron
Soporte motor	fundición
Support moteur	fonte
Girante	ottone (CH 160-310) ghisa (CH 350-550)
Impeller	brass (CH 160-310) cast iron (CH 350-550)
Rodete	latón (CH 160-310) fundición (CH 350-550)
Turbine	laiton (CH 160-310) fonte (CH 350-550)
Tenuta meccanica	ceramica-grafite
Mechanical seal	ceramic-graphite
Sello mecánico	cerámica-grafito
Garniture mécanique	céramique-graphite
Albero motore	acciaio AISI 303
Motor shaft	stainless steel AISI 303
Eje motor	acero AISI 303
Arbre moteur	acier AISI 303
Temperatura del liquido	
Liquid temperature	0 - 90 °C
Temperatura del líquido	
Température du liquide	
Pressione di esercizio	
Operating pressure	max 6 bar
Presión de trabajo	
Pression de fonctionnement	
MOTORE / MOTOR / MOTOR / MOTEUR	
Motore 2 poli a induzione	3~ 230/400V-50Hz
2 pole induction motor	1~ 230V-50Hz con termoprotettore
Motor de 2 polos a inducción	with thermal protection con protección térmica
Moteur à induction à 2 pôles	avec protection thermique
Classe di isolamento	
Insulation class	F
Clase de aislamiento	
Classe d'isolation	
Grado di protezione	
Protection degree	IP44
Grado de protección	
Protection	

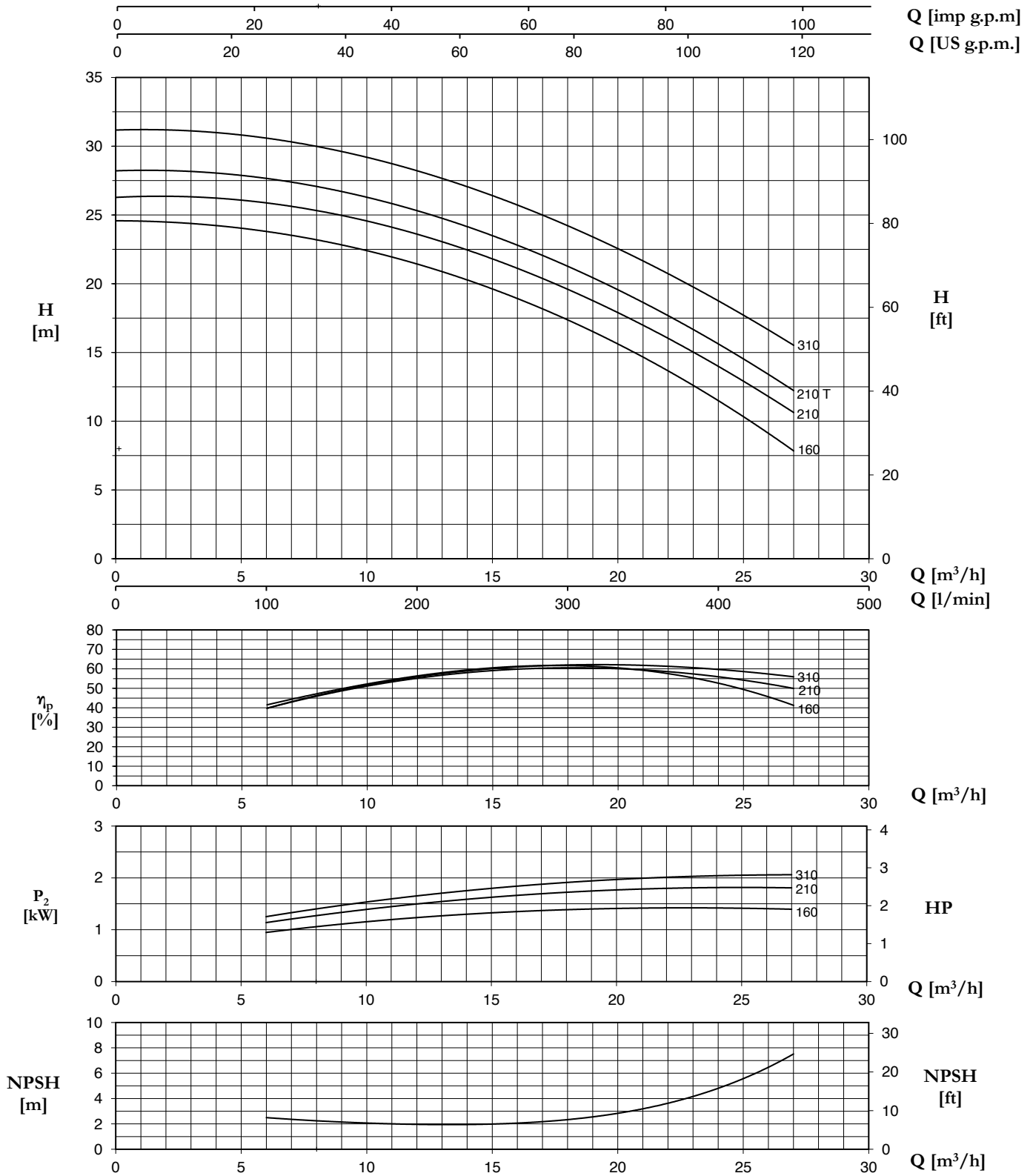

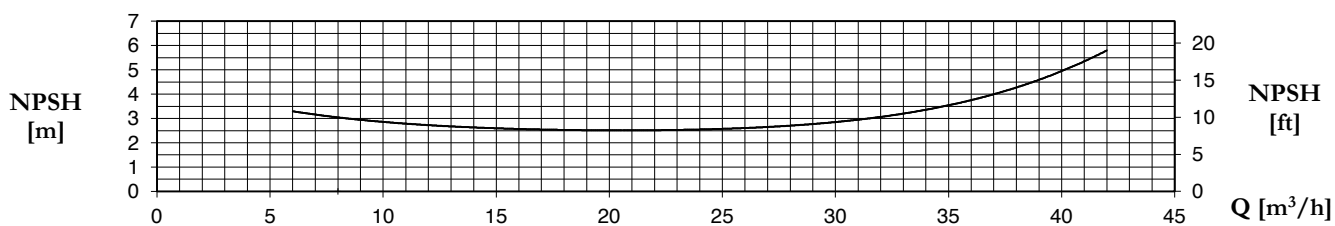
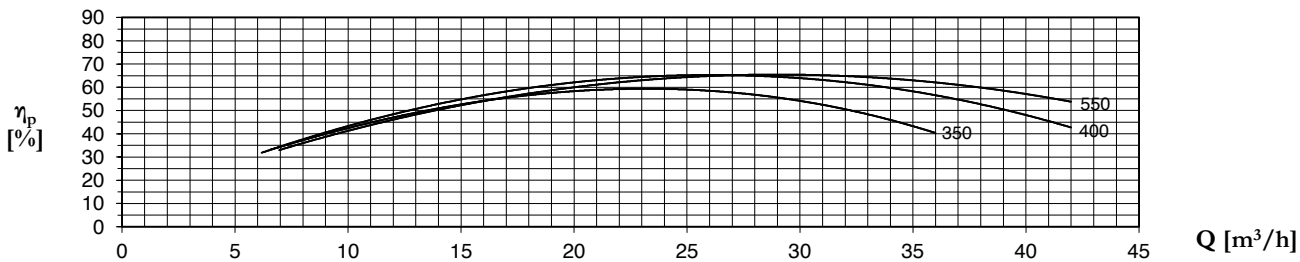
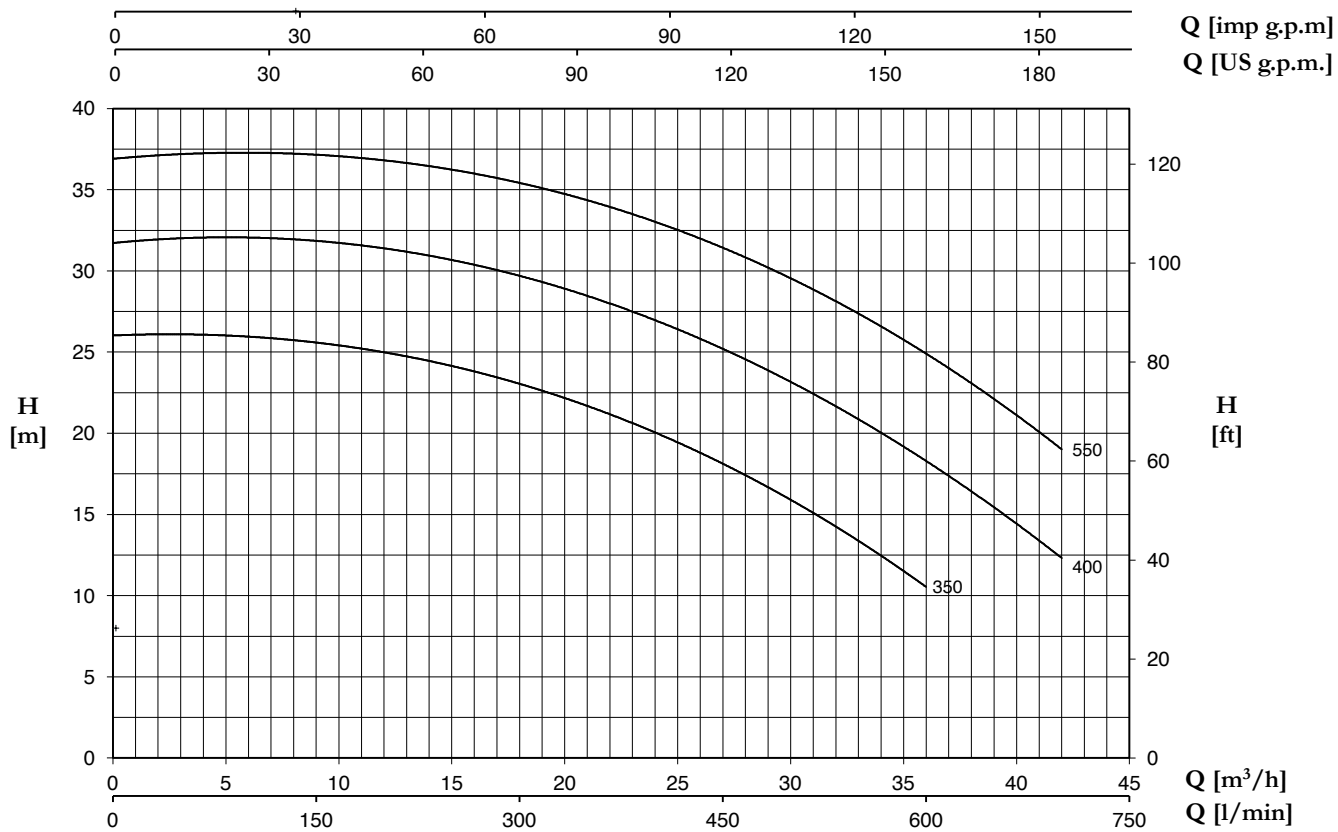

TYPE		P2		P1 (kW)		AMPERE		Q (m³/h - l/min)								
1~	3~					1~	3~	0	6	9	12	15	18	21	24	27
		(HP)	(kW)	1~	3~	1x230 V 50 Hz	3x400 V 50 Hz	H (m)								
CH 160	CHT 160	1,5	1,1	1,8	1,8	8,3	3,4	24,5	23,9	22,9	21,4	19,5	17,3	14,7	11,6	7,8
CH 210	-	2	1,5	2,1	-	10,1	-	26,3	25,9	25,0	23,6	21,7	19,6	17,1	14,1	10,6
-	CHT 210	2	1,5	-	2,2	-	4,7	28,2	27,6	26,7	25,3	23,5	21,3	18,6	15,6	12,2
CH 310	CHT 310	3	2,2	2,8	2,6	12,4	5,0	31,2	30,5	29,6	28,3	26,4	24,3	21,6	18,6	15,6

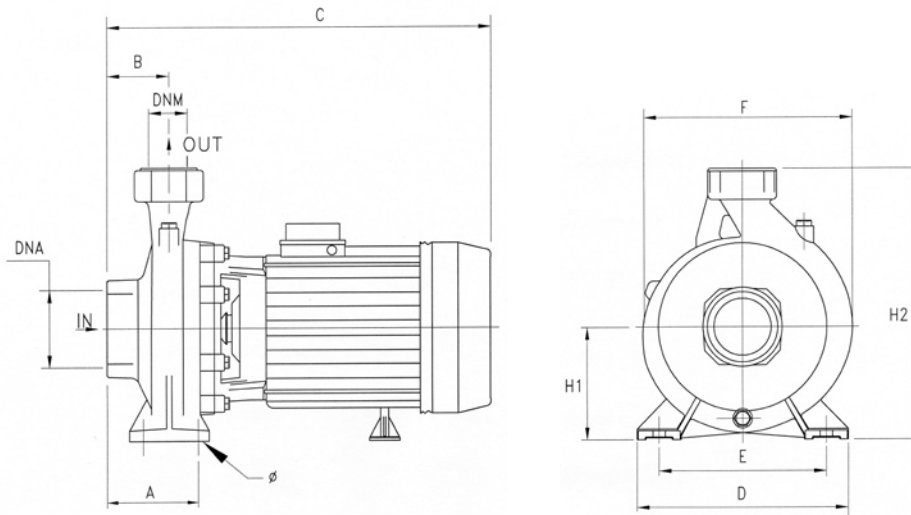

TYPE		P2		P1 (kW)		AMPERE		Q (m³/h - l/min)						
1~	3~	(HP)	(kW)	1~	3~	1~	3~	6	12	18	24	30	36	42
						1x230 V 50 Hz	3x400 V 50 Hz	100	200	300	400	500	600	700
								H (m)						
CH 350	CHT 350	3	2,2	2,95	2,84	13,5	5,1	26	25	23	20	16	10,5	-
CH 400	CHT 400	4	3	4,6	4,2	20,5	7,6	31,8	31,6	29,7	27	23	18,4	12,3
-	CHT 550	5,5	4	-	5,1	-	10	37	37	35,5	33	29,4	25	19



TYPE	DIMENSIONS (mm)														
	A	B	C	D	E	F	Ø	H1	H2	DNA	DNM	I	L		M
CH 160	105	48	370	200	160	215	9.5	110	280	2" G	2" G	390	230	300	22
CH 210	105	48	370	200	160	215	9.5	110	280	2" G	2" G	390	230	300	24
CH 310	105	48	410	200	160	215	9.5	110	280	2" G	2" G	430	230	300	32
CHT 310	105	48	370	200	160	215	9.5	110	280	2" G	2" G	390	230	300	26
CH 350	105	70	425	240	190	240	14	126	306	3" G	2" G	460	270	360	34,5
CHT 350	105	70	385	240	190	240	14	126	306	3" G	2" G	400	270	360	28,5
CH 400	105	70	445	240	190	240	14	126	306	3" G	2" G	460	270	360	38,7
CHT 400	105	70	425	240	190	240	14	126	306	3" G	2" G	460	270	360	33,2
CHT 550	105	70	445	240	190	240	14	126	306	3" G	2" G	460	270	360	38,7

TYPE				
	TRUCK		CONTAINER	
	PALLET (cm)	N° pumps	PALLET (cm)	N° pumps
CH 160-310	85x11x140	40	85x110x195	60
CH 350-550	85x110x150	30	85x110x180	30